

PARTS LIST MANUAL MODEL PAC-5



**Portable Air Compressor
Part No. 95100**



100 Thomas Johnson Drive, Frederick, MD 21702-4600 USA
Phone (301) 663-1600 • 1-800-638-3326
Fax (301) 663-1607 • 1-800-447-3326
Website: www.edcoinc.com • Email: sales@edcoinc.com

Printed in USA
©2004

READ AND UNDERSTAND THE OPERATORS INSTRUCTION MANUAL THOROUGHLY BEFORE ATTEMPTING TO OPERATE THIS EQUIPMENT. Death or serious injury could occur if this machine is used improperly.



SAFETY MESSAGES



The safety instructions are preceded by a graphic alert message of DANGER, WARNING, or CAUTION.



Indicates an imminent hazard which, if not avoided, will result in death or serious injury.



Indicates an imminent hazard which, if not avoided, can result in death or serious injury.



Indicates hazards which, if not avoided, could result in serious injury and or damage to the equipment.

GASOLINE

Powered Equipment



- Do not operate gasoline powered equipment without adequate ventilation. Carbon monoxide is an invisible, odorless gas that can kill.

ELECTRICAL

Powered Equipment



- ELECTRICAL HAZARD** - Be sure equipment is properly grounded. Failure to comply could kill or result in serious injury.



The engine exhaust from this product contains chemicals known to the State of California to cause cancer, birth defects or other reproductive harm.

GENERAL INSTRUCTIONS



- You must read and understand the operators instruction manual and all other manuals associated with this machine. For your safety and the safety of others around you, it is extremely important to fully understand how to operate this machine in the way it was intended. Different model machines or older/newer versions of the same model may have different parts and controls that you need to understand. If instructions are not readable or available DO NOT USE this machine and contact the factory for a replacement Manual.
- You must be able to physically handle the bulk weight and power of this machine. If not properly controlled this machine can cause death or serious injury.
- Do not operate this machine in an impaired mental state. You must be able to exercise good judgement and reactions to maintain a safe working environment.
- This is a "one person" machine which means only one operator can be operating the machine at any one time. For the safety of others, maintain a safe operating distance to other personnel. Your work area should be defined and appropriately marked so bystanders and coworkers do not stand or walk near this machine and end up seriously injured by flying debris or exposing them to harmful noise or dust.
- This equipment is for Commercial use. Although this is a "one person" machine your work team should understand how to shut this machine off and quickly get medical help if an accident strikes the operator.
- Keep all guards in place during operation. The guards are to provide protection from inadvertent contact with dangerous moving parts, pinch points, or hot surfaces.
- Wear appropriate Personal Protective Equipment (PPE) including safety glasses, safety boots, work gloves, respiratory protection, hearing protection, and head protection. Do not wear loose clothing that can get tangled in moving parts. Failure to do so could result in dismemberment or death. **Wear an approved respirator when removing hazardous materials or when grinding/cutting dry materials. Some dust particles such as concrete dust can contain silicate particles which can cause silicosis (a very serious lung disease). Contact NIOSH or OSHA for further details. When wet grinding/cutting, avoid contact with the concrete/asphalt slurry which can cause serious skin irritations.**
- You must maintain this machine per the maintenance schedule in the operator manual. Remember before adjusting, servicing, or fueling this machine, disconnect the source of power to the machine by disconnecting the spark plug (Gas models), or by unplugging the electrical power cord (electric models) or air hose (Pneumatic models) AT THE MACHINE so you can assure yourself it remains unplugged while you are working on it. Do not modify this machine. Use only genuine EDCO parts and accessories. Repairs and service should be performed by approved EDCO dealers or authorized technicians.
- You should look carefully around the area before you begin work so you can identify potential hazards such as deck inserts, pipes, columns, openings, electrical cords or outlets, or any other objects protruding from the slab surface.
- This machine has no brain so you must use your own. There is no substitute for safety. The safety decals on the machine are to serve as a reminder for information you must already know before you begin using this machine. Take a moment to reread the safety decals each time you use the machine. If your machine is missing any decals, contact the factory for a replacement (EDCO 1-800-638-3326).

PARTS LIST MANUAL

MODEL PAC-5

Section	Page Number
Safety Messages / General Instructions	2
How To Order Repair Parts	3
Illustration 1 : Main Grouping	4,5
Illustration 2 : Pump Assembly	6,7
Limited Equipment Warranty	back cover

HOW TO ORDER REPLACEMENT PARTS

- To insure product safety and reliability, always use genuine EDCO replacement parts when making repairs to the equipment.
- When calling for parts, specify the MODEL and SERIAL NUMBER of the machine which can be found on the NAME PLATE. Keep that information in the space provided. In addition to this information, give part number, description and quantity as listed on the parts list to your parts representative.
- Please note: Due to improvements and changes in the equipment, the illustrations shown may be different than the actual machine.

FILL IN INFORMATION BELOW

Date of Purchase _____
 Name of Machine _____
 Model # _____
 Serial # _____
 Belt Size(s) _____

Toll Free: 1-800-638-3326
 FAX: 1-800-447-3326
 email: sales@edcoinc.com
www.edcoinc.com



ILLUSTRATION 1 : MAIN GROUPING

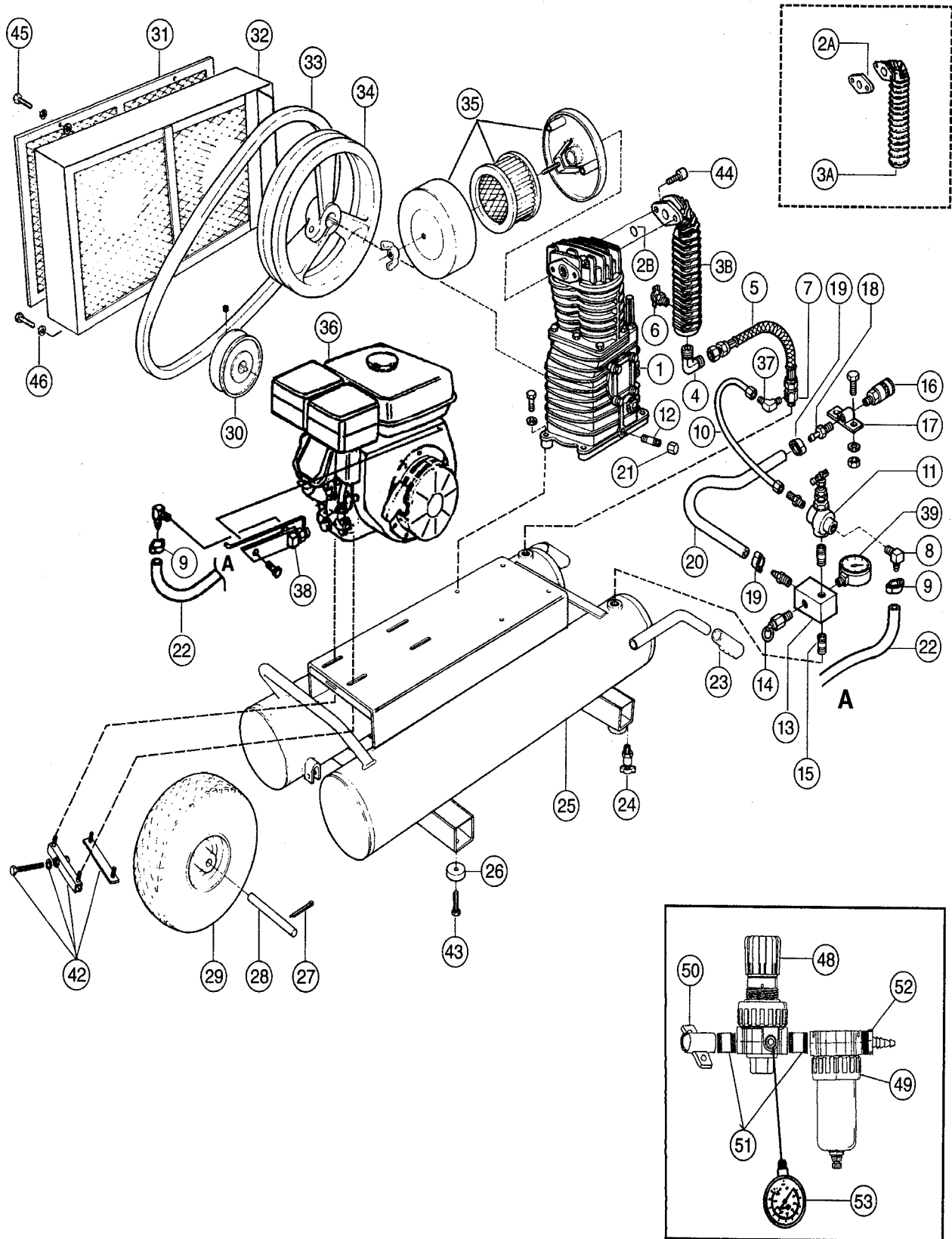

PARTS LISTING - ILLUSTRATION 1 : MAIN GROUPING			
ITEM#	PART#	DESCRIPTION	QTY.
1	RAPMP12K17CH	TWIN CYLINDER PUMP WITH FLYWHEEL	1
	RAPMP12K17CHLF	TWIN CYLINDER PUMP LESS FLYWHEEL	1
2A	RA30501490CH	GASKET	1
2B	RA30502510CH	"O" RING-AFTERCOOLER	1
3A	RA32901460CH	AFTERCOOLER	1
3B	RA3290146ACH	AFTERCOOLER "O" RING STYLE	1
4	RA145D	BRASS ELBOW	1
5	RA145F	8-1/2" FLEXIBLE DISCHARGE HOSE W/ FITTING	1
6	RA132	1/4" DRAIN COCK	1
7	RACV4X4TA	1/2" CHECK VALVE	1
8	RABREL0250X0125H16	BRASS ELBOW	2
9	RA177	HOSE CLAMP	2
10	RA178D	1/4" NYLON TUBE (WITHOUT FITTINGS)	1
	RABRNT0250	1/4" BRASS NUT	2
	RABRSL0250	1/4" BRASS SLEEVE	2
	RABRRG0250	1/4" BRASS RING	2
11	RA131B	PILOT UNLOADER VALVE	1
	RA131BM	FELT MUFFLER	1
	RA131BR	RETAINER RING	1
12	RABLNP0250X1500	NIPPLE	1
13	RA154	ALUMINUM BLOCK MANIFOLD	1
14	RASRV0250N165	SAFETY RELIEF VALVE	1
15	RABLNP0500X1500	NIPPLE	1
16	RA309A	QUICK COUPLER	1
17	RA210	ACCESSORY OUTLET BRACKET	1
18	RABRCP0375X0375H12	3/8" BRASS COUPLER	2
19	RA177A	HOSE CLAMP FOR 3/8" AIR HOSE	2
20	RA178A	3/8" RUBBER HOSE	1
21	RABLCA0250	1/4" CAP	1
22	RA178	1/4" RUBBER HOSE	1
23	RA328	RUBBER HANDLE GRIP	2
24	RA132B	1/4" DRAIN COCK	2
25	RATNKASY4090K17	TWIN TANK ASSEMBLY	1
26	RA219	RUBBER VIBRATION PAD (FEET)	4
27	RA181A	COTTER PIN	2
28	RA181	AXLE	1
29	RAWLS30	FULLY PNEUMATIC WHEEL	1
30	RAPUAK44X0750	ENGINE PULLEY	1
31	RABG8145	BELT GUARD COVER	1
32	RABG8140B	BELT GUARD BASE	1
33	RABT4L510	BELT	1
34	RA31007280CH	PUMP FLYWHEEL	1
35	RAFS14050	FILTER/SILENCER ASSEMBLY	1
	RA431	REPLACEMENT FILTER ELEMENT	1
36	15051	ENGINE, HONDA 5.5 HP GX160K1-QX2	1
37	RABREL0250X012539	BRASS ELBOW	1
38	RA192EGX160K1QX	THROTTLE CONTROL KIT	1
39	RAGA0250200	PRESSURE GAGE	1
42	RASBT5HP	BELT TIGHTENING DEVICE	1
43	RAMIS10008	1/4"x1" SELF-TAPPING SCREW	4
44	RA37302530CH	AFTERCOOLER BOLT	2
45	RAMIS10094	SPIN LOCK BOLT	5
46	RAMIS10022	5/16"x7/8" BOLT	2
	RAMIS10099	5/16" LOCKWASHER	2
	RAMIS10108	5/16"x1-3/8" FLATWASHER	2
47	N/A	NO ITEM	-
48	RAREG0375	3/8" REGULATOR	1
49	RAFIL0375	3/8" FILTER (WATER TRAP)	1
50	RA210	ACCESSORY OUTLET BRACKET	1
51	RABLNP0375X1500	3/8"x1-1/2" NIPPLE	3
52	RABRCP0375X0375H12	3/8" BRASS BARB COUPLING	1
53	RAGA0250200	1/4" PRESSURE GAGE, 200 PSI	1



100 Thomas Johnson Drive, Frederick, MD 21702-4600 USA
 Phone (301) 663-1600 • 1-800-638-3326
 Fax (301) 663-1607 • 1-800-447-3326
 Website: www.edcoinc.com • Email: sales@edcoinc.com

Printed in USA
 ©2004

ILLUSTRATION 2 : PUMP ASSEMBLY

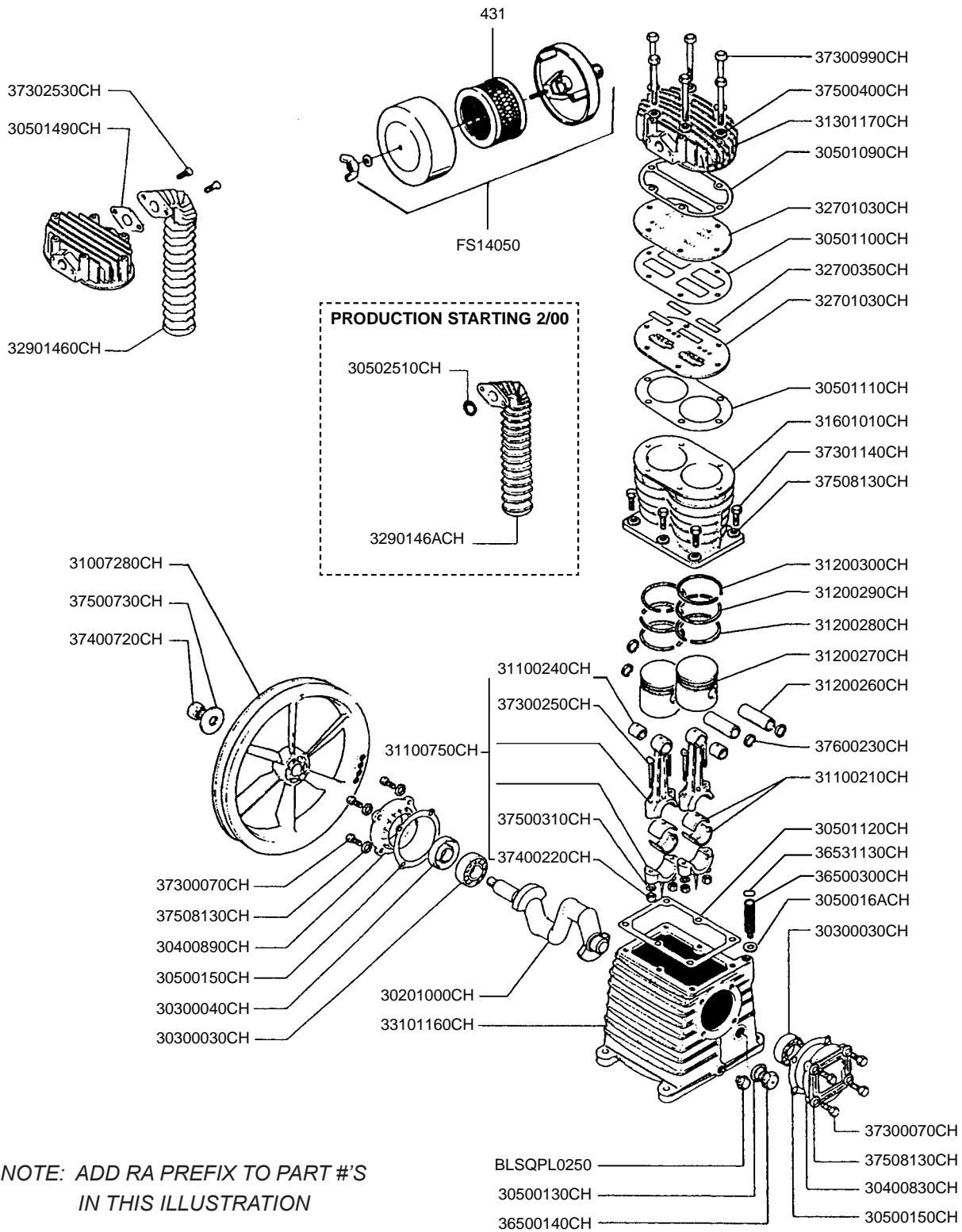

**NOTE: ADD RA PREFIX TO PART #'S
IN THIS ILLUSTRATION**



PARTS LISTING - ILLUSTRATION 2 : PUMP ASSEMBLY		
PART#	DESCRIPTION	QTY.
RA30201000CH	CRANKSHAFT	1
RA30300030CH	BALL BEARING	2
RA30300040CH	OIL SEAL	1
RA30400830CH	BEARING CARRIER	1
RA30400890CH	BEARING CARRIER	1
RA30500130CH	GASKET	1
RA30500150CH	GASKET	2
RA3050016ACH	3/8" HOLE GASKET	1
RA30501090CH	GASKET	1
RA30501100CH	GASKET	1
RA30501110CH	GASKET	1
RA30501120CH	GASKET	1
RA30501490CH	GASKET	1
RA31007280CH	PUMP FLYWHEEL	1
RA31100210CH	BEARING SHELL	2
RA31100240CH	BUSHING*	2
RA31100750CH	CONNECTING ROD W/ UPPER BUSHING	2
RA31100750CH1	CONNECTING ROD W/ UPPER BUSHING & BEARING SHELL	2
RA31200260CH	PISTON PIN	2
RA31200270CH	PISTON	2
RA31200280CH	SLOTTED OIL RING	2
RA31200290CH	STEPPED SCRAPER RING	2
RA31200300CH	COMPRESSION RING	2
RA31301170CH	CYLINDER HEAD	1
RA31601010CH	CYLINDER	1
RA32700350CH	VALVE	4
RA32701030CH	VALVE PLATE	2
RA32901460CH	AFTERCOOLER	1
RA33101160CH	CRANKCASE	1
RA36500140CH	OIL SIGHT GAGE	1
RA36500300CH	3/8" BREATHER/OIL FILL PLUG	1
RA36531130CH	RED CAP FOR 3/8" BREATHER/OIL FILL PLUG	1
RA37300070CH	BOLT	8
RA37300250CH	BOLT	4
RA37300990CH	BOLT	6
RA37301140CH	BOLT	6
RA37302530CH	AFTERCOOLER BOLT	2
RA37400220CH	NUT	4
RA37400720CH	NUT	1
RA37500310CH	WASHER	4
RA37500400CH	WASHER	6
RA37500730CH	WASHER	1
RA37508130CH	WASHER	14
RA37600230CH	SNAP RING	4
RA431	REPLACEMENT FILTER ELEMENT	1
RABLSQPL0250	1/4" SQUARE HEAD PLUG	1
RAFS14050	FILTER/SILENCER ASSEMBLY	1
RAK17RINGS	RING SET	1
RAK17GASKETS	GASKET SET	1
RA1700VK17	VALVE PLATE ASSY. (VALVE PLATES, REEDS, & UPPER THREE GASKETS)	1
RA1700PK17	PISTON ASSY. (PISTON, RINGS, PISTON PIN & SNAP RINGS)	2
RA30502510CH	"O" RING - AFTERCOOLER	1
RA3290146ACH	AFTERCOOLER	1



100 Thomas Johnson Drive, Frederick, MD 21702-4600 USA
 Phone (301) 663-1600 • 1-800-638-3326
 Fax (301) 663-1607 • 1-800-447-3326
 Website: www.edcoinc.com • Email: sales@edcoinc.com

Printed in USA
 ©2004

LIMITED EQUIPMENT WARRANTY

Equipment Development Company, Inc. herein referred to as EDCO warrants that each new unit manufactured by EDCO to be free from defects in material and workmanship in normal use and service for a period of (1) one year (except in the case of the cutter drum assembly on all model concrete asphalt planes, in which case the warranty period shall be 90 days) from date of shipment to the original buyer or equipment rental center owner.

EDCO will, at its option, repair or replace, at the EDCO factory or at a point designated by EDCO any part, which shall appear to the satisfaction of EDCO inspection to have been defective in material or workmanship.

This warranty, does not apply to failure occurring as a result of abuse, misuse, negligent repairs, corrosion, erosion, normal wear and tear, alterations or modifications made to the product without express written consent of EDCO: or failure to follow the recommended operating practices and maintenance procedures as provided in the products operating and maintenance manuals.

This warranty does not obligate EDCO to bear any transportation charges in connection with the replacement or repair of defective parts. This warranty does not obligate EDCO to bear any expense for travel time or of personnel in connection with any service calls.

Accessories or equipment furnished and installed on the product by EDCO but manufactured by others, including but not limited to engines, motors, electrical equipment, transmissions, etc., shall carry the accessory manufacturers' own warranty.

THIS WARRANTY IS IN LIEU OF ALL OTHER WARRANTIES, EXPRESSED OR IMPLIED, OR STATUTORY, INCLUDING ANY WARRANTIES OF MERCHANTABILITY OR OF FITNESS FOR A PARTICULAR PURPOSE.

LIABILITY LIMITATIONS

The remedies of the user set forth under provisions of warranty outlined above are the exclusive and total liability of EDCO with the respect to their sale or the equipment and service furnished hereunder, in connection with the performance or breach thereof, or from the sale, delivery, installation, repair or technical direction covered by or furnished under the sale, whether based on contract, warranty, negligence, indemnity, strict liability, or otherwise shall not exceed the purchase price of the unit of equipment upon which such liability is based.

EDCO will not in any event be liable to the user, any successors in interest or any beneficiary or assignee relating to this sale for any consequential, incidental, indirect, special or punitive damages arising out of this sale or any breach thereof, or any defects on, or failure of, or malfunction of the equipment under this sale based upon loss of use, lost profits or revenue, interest, lost goodwill, work stoppage, impairment of other goods, loss by reason of shutdown or non-operation, increased expenses of operation of the equipment, cost of purchase or replacement power of claims of users or customers of the user for service interruption whether or not such loss or damage is based on contract, warranty, negligence, indemnity, strict liability, or otherwise.

EDCO reserves the right to modify, alter and improve any part or parts without incurring any obligation to replace any part or parts previously sold without such modified, altered or improved part or parts.

No person is authorized to give any other warranty or to assume any additional obligation on EDCO's behalf unless made in writing and signed by an officer of EDCO.

Equipment Development Company, Inc.

USE ONLY GENUINE EDCO PARTS AND ACCESSORIES

For your own safety, the safety of others and the life of your machine

